

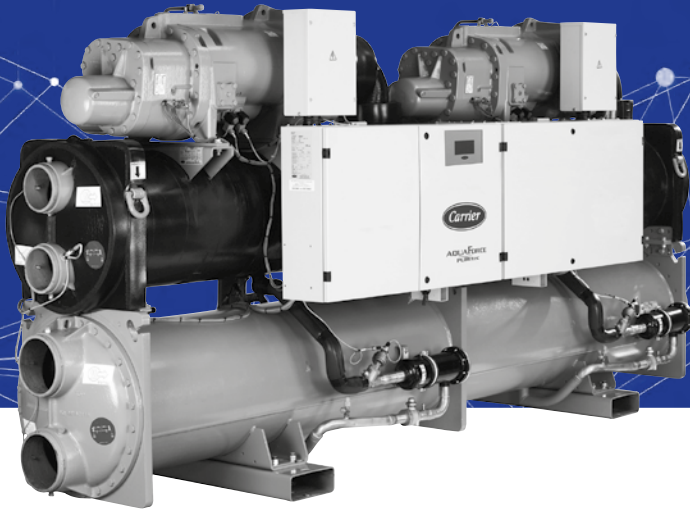

United Technologies

PRODUCT SELECTION DATA

WATER-COOLED SCREW CHILLERS WATER-SOURCED SCREW HEAT PUMPS



Low energy consumption
High reliability
Safe Design
Easy and fast installation
Minimised operating sound levels
Environmental care

30XW-PZE/30XWHPZE-A

AQUAFORCE
PUREtec

Nominal cooling capacity 269-1110 kW
Nominal heating capacity 319-1296 kW

The 30XW-PZE liquid chillers are the premium solution for industrial and commercial applications where installers, consultants and building owners require optimal performances and maximum quality.

The 30XW-PZE liquid chillers are designed to meet current and future requirements in terms of energy efficiency, flexibility of use and compactness. They use the most reliable technologies available today:

- Twin-rotor screw compressors with a variable capacity valve
- R-1234ze refrigerant
- Touch Pilot control system
- Flooded heat exchangers that are mechanically cleanable

The AquaForce PUREtec range is splitted into two versions:

- 30XW-PZE for air conditioning and refrigeration applications
- 30XWHPZE for heating applications

As standard, the unit can provide an evaporator leaving temperature down to 3,3°C, and when operating as a heat pump, it can deliver up to 55°C (70°C optional) on the condenser side.



CARRIER participates in the ECP programme for LCP/HP
Check ongoing validity of certificate:
www.eurovent-certification.com

CUSTOMER BENEFITS

Low energy consumption

- 30XW-PZE range is compliant with EU Eco-design Minimum Efficiency Performance Standards (MEPS) in cooling that apply from January 2018
- SEER 12/7°C up to 7.3 and SEPR 12/7°C up to 9.3
- 30XWHPZE range is compliant with EU Eco-design Minimum Efficiency Performance Standards (MEPS) in heating that apply from September 2015
- COP of up to 6.7 and SCOP up to 6,5
- The high energy efficiency is reached through:
 - Twin-rotor screw compressor equipped with a high-efficiency motor and a variable capacity valve that permits exact matching of the cooling capacity to the load.
 - Flooded multi-pipe heat exchangers for increased heat exchange efficiency.
 - Electronic expansion device permitting operation at a lower condensing pressure and improved utilisation of the evaporator heat exchange surface.
 - Economizer system with electronic expansion device for increased cooling capacity.

Low operating sound levels

- Standard unit features include:
 - Silencers on the compressors discharge line.
 - Silencers on the economiser return line.
 - Acoustic insulation on the components that are most subjected to radiated noise.
 - Option 257 further reduces the global unit sound level.

Easy and fast installation

- Compact design
 - The 30XW units are designed to offer the most compact dimensions on the market.
 - With a width of approximately 1 m up to 1300 kW the units can pass through standard door openings and only require minimum floor space in the plant room.

Compact, accessible unit - side view - sizes up to 1300 KW

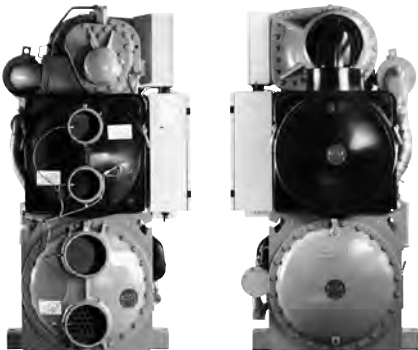

- Simplified electrical connections
 - Main disconnect switch with high trip capacity
 - Transformer to supply the integrated control circuit (400/24 V)
- Simplified hydraulic connections
 - Victaulic connections on the evaporator and condenser
 - Practical reference marks for entering and leaving water connections
 - Possibility to reverse the heat exchanger water inlet and outlet at the factory
 - Possibility to modify the number of heat exchanger passes

- Fast commissioning
 - Systematic factory operation test before shipment
 - Quick-test function for step-by-step verification of the instruments, expansion devices and compressors.

Environmental care



- R-1234ze long-term refrigerant solution
 - HFO refrigerant with nearly zero global warming potential (GWP < 1) and zero ozone depletion potential (ODP = 0).
 - Not impacted by the HFC phase-down plan in Europe (79% HFC reduction in EU member states at 2030 horizon)
 - Compliant with refrigerant regulation in Switzerland that bans the use of HFC refrigerant in large capacity air-conditioning equipment.
- Leak-tight refrigerant circuit
 - Reduction of leaks as no capillary tubes and flare connections are used
 - Verification of pressure transducers and temperature sensors without transferring refrigerant charge
 - Discharge line shut-off valve and liquid line service valve for simplified maintenance.

High reliability and easy servicing

- The 30XW units offer increased global performance as well as Carrier's acclaimed product quality and reliability.
- Major components are selected and tested with R-1234ze refrigerant to minimize failures possibility, as well as many design choices have been taken in this perspective.
- Screw compressors
 - Industrial-type screw compressors with oversized bearings and motor cooled by suction gas.
 - All compressor components are easily accessible on site minimising down-time.
- Refrigerant circuit
 - Two independent refrigerant circuits (from 1000 kW upwards); the second one automatically takes over, if the first one develops a fault, maintaining partial cooling under all circumstances.
- Evaporator
 - Electronic paddle-free flow switch. Auto-setting according to cooler size and fluid type.
- Auto-adaptive control
 - Control algorithm prevents excessive compressor cycling (Carrier patent)
 - Automatic compressor unloading in case of abnormally high condensing pressure.
- Exceptional endurance tests
 - Partnerships with specialised laboratories and use of limit simulation tools (finite element calculation) for the design of critical components.
 - Transport simulation test in the laboratory on a vibrating table and then on an endurance circuit (based on a military standard).

CUSTOMER BENEFITS

Safe Design

- Specific polyol ester oil qualified by Carrier for using with HFO-1234ze to guarantee and maintain reliable bearing lubrication.
- Specific compressor gaskets compatible with HFO-1234ze, tested and validated by Carrier.
- New relief valves designed for operation with HFO-1234ze
- Specific electrical box with increased tightness and integrated blower that maintains positive air pressure to avoid any risk of ignition.
- New control algorithms
- Specific documentation that contains all the installation, operation, maintenance and safety Instructions.

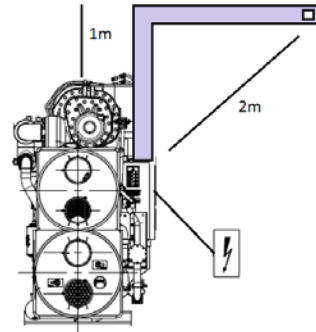

TECHNICAL INSIGHTS

Touch Pilot Control

Touch Pilot control, 5" user interface



- New innovative smart control features:
 - An intuitive and user-friendly, coloured, 5" interface (7" optional)
 - Direct access to the unit's technical drawings and the main service documents
 - Screen-shots with concise and clear information in local languages
 - Complete menu, customised for different users (end user, service personnel and Carrier-factory technicians)
 - Easy access to the controller box with inclined touch screen mounting to ensure legibility under any lighting conditions
 - Safe operation and unit setting: password protection ensures that unauthorised people cannot modify any advanced parameters
 - Simple and "smart" intelligence uses data collection from the constant monitoring of all machine parameters to optimise unit operation.
- Energy management:
 - Internal time schedule clock controls chiller on/off times and operation at a second set-point
 - The DCT (Data Collection Tool) records the alarms history to simplify and facilitate service operations.

Remote Management (Standard)

- Units with Touch Pilot control can be easily accessed from the internet, using a PC with an Ethernet connection. This makes remote control quick and easy and offers significant advantages for service operations.
- The 30XW also communicates with other building management systems via optional communication gateways.
- The 30XW is equipped with an RS485 serial port that offers multiple remote control, monitoring and diagnostic possibilities. Carrier offers a vast choice of control products, specially designed to control, manage and supervise the operation of an air conditioning system. Please consult your Carrier representative for more information.
- The following commands/visualisations are possible from remote connection:
 - Condenser pumps control: a digital input allows verification of condenser water flow (the flow switch must be supplied by the installer)
 - Start/stop of the machine
 - Dual set-point management: through a dedicated contact is possible to activate a second set-point (example: unoccupied mode)
 - Demand limit setting: to limit the maximum chiller capacity to a predefined value
 - Operation visualization: indication if the unit is operating or if it's in stand-by (no cooling load)
 - alarm visualization.

Remote management (EMM option)

- The Energy Management Module offers extended remote control possibilities:
 - Room temperature: permits set-point reset based on the building indoor air temperature (with Carrier thermostat)
 - Set point reset: ensures reset of the cooling set-point based on a 4-20 mA signal
 - Demand limit: permits limitation of the maximum chiller power or current based on a 4-20 mA signal
 - Demand limit 1 and 2: closing of these contacts limits the maximum chiller power or current to two predefined values

TECHNICAL INSIGHTS

- User safety: this contact can be used for any customer safety loop; opening of the contact generates a specific alarm
- Ice storage end: when ice storage has finished, this input permits return to the second set-point (unoccupied mode)
- Time schedule override: closing of this contact cancels the time schedule effects
- Out of service: this signal indicates that the chiller is completely out of service
- Chiller capacity: this analogue output (0-10 V) gives an immediate indication of the chiller capacity
- Alert indication: this volt-free contact indicates the necessity to carry out a maintenance operation or the presence of a minor fault.

06T screw compressor

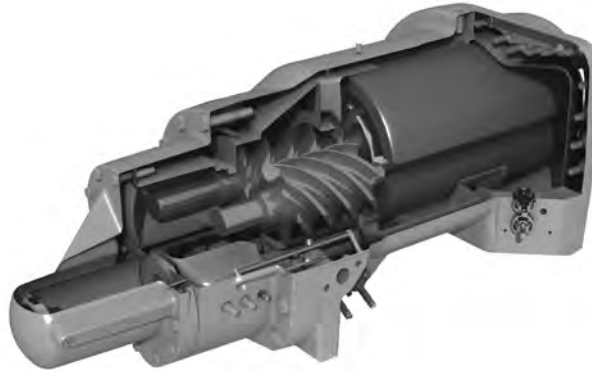

The Carrier 06T screw compressor designed for operation with HFO-1234ze refrigerant benefits from Carrier's long experience in the development of twin-rotor screw compressors. The compressor is equipped with bearings with oversized rollers, oil pressure lubricated for reliable and durable operation, even at maximum load.

A variable control valve controlled by the oil pressure permits infinitely variable cooling capacity. This system allows optimal adjustment of the compressor cooling capacity and ensures exceptionally high stability of the chilled water leaving temperature.

Among the other advantages: if a fault occurs e.g. if the condenser is fouled or at very high water temperature, the compressor does not switch off, but continues operation with a reduced capacity (unloaded mode).

The silencer in the discharge line considerably reduces discharge gas pulsations for much quieter operation.

The condenser includes an oil separator that minimises the amount of oil in circulation in the refrigerant circuit and re-directs it to the compressor function.

OPTIONS

Options	N°	Description	Advantages	Use
Light-brine solution, down to -3°C	8	Implementation of new algorithms of control to allow chilled brine solution production down to -3°C when ethylene glycol is used (0°C with propylene glycol)	Matches with most application requirements for ground-sourced heat pumps and fits with many industrial processes requirements	301-1101
Master/slave operation	58	Unit equipped with supplementary water outlet temperature sensor kit to be field-installed allowing master/slave operation of two units connected in parallel	Optimised operation of two units connected in parallel operation with operating time equalisation	301-1101
Single power connection point	81	Unit power connection via one main supply connection	Quick and easy installation	801-1101
No disc.switch but short circ.protection	82A	Unit without disconnect switch, but with short-circuit protection device	Permits an external electrical disconnect system for the unit (field-supplied), while ensuring unit short circuit protection	301-1101
Evap. pump power/control circuit	84	Unit equipped with an electrical power and control circuit for one pump evaporator side	Quick and easy installation: the control of fixed speed pumps is embedded in the unit control	301-1001
Evap. dual pumps power/control circuit	84D	Unit equipped with an electrical power and control circuit for two pumps evaporator side	Quick and easy installation: the control of fixed speed pumps is embedded in the unit control	301-1001
Cond. pump power/control circuit	84R	Unit equipped with an electrical power and control circuit for one pump condenser side	Quick and easy installation: the control of fixed speed pumps is embedded in the unit control	301-1001
Condenser insulation	86	Thermal condenser insulation	Minimizes thermal dispersions condenser side (key option for heat pump or heat recovery applications) and allows compliancy with special installation criteria (hot parts insulated)	301-1101
Service valve set	92	Liquid line valve (evaporator inlet) and compressor suction line valve	Allow isolation of various refrigerant circuit components for simplified service and maintenance	301-1101
Evaporator with one pass less	100C	Evaporator with one pass on the water side. Evaporator inlet and outlet on opposite sides.	Easy to install, depending on site. Reduced pressure drops	301-1101
Condenser with one pass less	102C	Condenser with one pass on the water side. Condenser inlet and outlet on opposite sides.	Easy to install, depending on site. Reduced pressure drops	301-1101
21 bar evaporator	104	Reinforced evaporator for extension of the maximum water-side service pressure to 21 bar (standard 10 bar)	Covers applications with a high water column evaporator side (typically high buildings)	301-1101
21 bar condenser	104A	Reinforced condenser for extension of the maximum water-side service pressure to 21 bar (standard 10 bar)	Covers applications with a high water column condenser side (typically high buildings)	301-1101
Reversed evaporator water connections	107	Evaporator with reversed water inlet/outlet	Easy installation on sites with specific requirements	301-1101
Reversed condenser water connections	107A	Condenser with reversed water inlet/outlet	Easy installation on sites with specific requirements	301-1101
J-Bus gateway	148B	Two-directional communication board complying with JBus protocol	Connects the unit by communication bus to a building management system	301-1101
Lon gateway	148D	Two-directional communication board complying with Lon Talk protocol	Connects the unit by communication bus to a building management system	301-1101
Bacnet over IP	149	Two-directional high-speed communication using BACnet protocol over Ethernet network (IP)	Easy and high-speed connection by ethernet line to a building management system. Allows access to multiple unit parameters	301-1101
High condensing temperature	150	Optimized compressor for operation at high condensing temperature	Increased condenser leaving water temperature up to 70°C. Allows applications with high condensing temperature (heat pumps, installations with not generously sized dry-coolers or more generally, installations with dry-coolers in hot climate). NOTE: to ensure control of the condenser leaving water temperature, this option must be fitted with 30XWH units.	301-1101
Condensing temperature limitation	150B	Limitation of the maximum condenser leaving water temperature to 45°C	Reduced maximum power input and current absorption: power cables and protection elements can therefore be downsized	301-1101
Control for low cond. temperature systems	152	Output signal (0-10 V) to control the condenser water inlet valve	Simple installation: for applications with cold water at condenser inlet (ex. ground-source, groundwater-source, superficial water-source applications) the signal permits to control a 2 or 3-way valve to maintain condenser water temperature (and so condensing pressure) at acceptable values	301-1101

OPTIONS

Options	N°	Description	Advantages	Use
Energy Management Module	156	EMM Control board with additional inputs/outputs. See Energy Management Module option chapter	Extended remote control capabilities (Set-point reset, ice storage end, demand limits, boiler on/off command...)	301-1101
Touch Pilot control, 7" user interface	158A	Touch Pilot control supplied with a 7 inch colour touch screen user interface	Enhanced ease of use.	301-1101
Compliance with Swiss regulations	197	Additional tests on the water heat exchangers: supply (additional of PED documents) supplementary certificates and test certifications	Conformance with Swiss regulations	301-1101
Compliance with Australian regulations	200	Unit approved to Australian code	Conformance with Australian regulations	301-1101
Low noise level	257	Evaporator sound insulation	3 dB(A) quieter than standard unit	401-1101
Welded evaporator connection kit	266	Victaulic piping connections with welded joints	Easy installation	301-1101
Welded condenser water connection kit	267	Victaulic piping connections with welded joints	Easy installation	301-1101
Flanged evaporator water connection kit	268	Victaulic piping connections with flanged joints	Easy installation	301-1101
Flanged condenser water connection kit	269	Victaulic piping connections with flanged joints	Easy installation	301-1101
Thermal compressor insulation	271	The compressor is covered with a thermal insulation layer	Prevents air humidity to condensate on the compressor surface	301-1101
Carrier Connect link (BSS regions only)	298	3G router board NOTE 1: require option 149 NOTE 2: when more than one machine is installed on site, only one of them shall be equipped with option 298 while all of them must be equipped with option 149 NOTE 3: if the Carrier® PlantCTRL™ is on site, option 298 shall be integrated in the Carrier® PlantCTRL™ while option 149 is still mandatory for each single unit.	Enabler for Carrier Connect service offer	301-1101

PHYSICAL DATA, STANDARD UNITS

30XW-PZE / 30XWHPZE	301	401	451	551	601	651	801	901	1001	1101
---------------------	-----	-----	-----	-----	-----	-----	-----	-----	------	------

Heating

Standard unit Full load performances*	HW1	Nominal capacity	kW	319	440	501	642	714	785	894	1035	1191	1296
		COP	kW/kW	6,23	6,43	6,42	6,65	6,53	6,39	6,62	6,63	6,61	6,36
	HW2	Nominal capacity	kW	315	433	492	630	701	766	876	1011	1165	1268
		COP	kW/kW	4,74	4,86	4,85	5,00	4,89	4,84	5,02	5,03	5,03	4,84
	HW3	Nominal capacity	kW	311	427	485	621	690	747	862	992	1144	1242
		COP	kW/kW	3,70	3,74	3,75	3,82	3,75	3,76	3,85	3,87	3,89	3,73
Seasonal energy efficiency**	HW1	SCOP _{30/35°C}	kW/kW	6,41	6,66	6,72	6,79	6,68	6,68	6,88	6,95	6,73	6,53
		η _{s heat} _{30/35°C}	%	237	251	253	256	251	251	259	261	253	245
	HW3	SCOP _{47/55°C}	kW/kW	4,43	4,88	4,82	4,62	4,64	4,73	5,14	5,14	4,86	4,64
		η _{s heat} _{47/55°C}	%	164	183	181	173	174	177	193	193	182	174
	P _{rated}		kW	414	546	619	796	848	913	1113	1228	1413	1567

Cooling

Standard unit Full load performances*	CW1	Nominal capacity	kW	269	375	427	550	610	668	766	892	1026	1110
		EER	kW/kW	5,39	5,58	5,60	5,83	5,72	5,60	5,85	5,96	5,94	5,71
		Eurovent class		A	A	A	A	A	A	A	A	A	A
	CW2	Nominal capacity	kW	378	536	611	787	869	941	1096	1275	1466	1588
		EER	kW/kW	7,62	7,85	7,94	8,33	8,04	7,54	8,30	8,35	8,28	7,91
		Eurovent class		A	A	A	A	A	A	A	A	A	A
Seasonal energy efficiency	SEER_{12/7°C} Comfort low temp.		kWh/kWh	5,70	5,81	6,07	6,58	6,44	6,44	6,82	7,29	7,06	6,90
	η_{s cool}_{12/7°C}		%	225	230	240	260	254	255	270	289	279	273
	SEPR_{12/7°C} Process high temp.		kWh/kWh	8,98	8,66	8,84	9,25	8,72	8,42	8,68	9,10	9,27	9,00
	SEER _{23/18°C} Comfort medium temp.		kWh/kWh	7,23	7,32	7,41	8,45	7,85	7,93	8,34	8,57	8,46	8,15

* In accordance with standard EN14511-3:2013

** In accordance with standard EN14825:2013, average climate

HW1 Heating mode conditions: Evaporator entering/leaving water temperature 10°C/7°C, condenser entering/leaving water temperature 30°C/35°C, evaporator and condenser fouling factor 0 m². k/W

HW2 Heating mode conditions: Evaporator entering/leaving water temperature 10°C/7°C, condenser entering/leaving water temperature 40°C/45°C, evaporator and condenser fouling factor 0 m². k/W

HW3 Heating mode conditions: Evaporator entering/leaving water temperature 10°C/7°C, condenser entering/leaving water temperature 47°C/55°C, evaporator and condenser fouling factor 0 m². k/W

CW1 Cooling mode conditions: Evaporator water entering/leaving temperature 12°C/7°C, condenser entering/leaving water temperature 30°C/35°C, evaporator and condenser fouling factor 0 m².K/W

CW2 Cooling mode conditions: Evaporator water entering/leaving temperature 23°C/18°C, condenser entering/leaving water temperature 30°C/35°C, evaporator and condenser fouling factor 0 m².K/W

η_{s heat}_{30/35°C} & SCOP_{30/35°C} Applicable Ecodesign regulation: (EU) No 813/2013

η_{s heat}_{47/55°C} & SCOP_{47/55°C} Applicable Ecodesign regulation: (EU) No 813/2013

η_{s cool}_{12/7°C} & SEER_{12/7°C} **Réglementation Ecodesign applicable (UE) No 2016/2281**

SEPR_{12/7°C} **Réglementation Ecodesign applicable (UE) No 2016/2281**

SEER_{23/18°C} Réglementation Ecodesign applicable (UE) No 2016/2281



Eurovent certified values

PHYSICAL DATA, STANDARD UNITS

30XW-PZE / 30XWHPZE		301	401	451	551	601	651	801	901	1001	1101
Sound levels - standard unit											
Sound power level ⁽¹⁾	dB(A)	93	97	97	97	97	97	100	100	100	100
Sound pressure level at 1 m ⁽²⁾	dB(A)	76	80	80	79	79	79	81	81	81	81
Sound levels - standard unit + option 257 ⁽³⁾											
Sound power level ⁽¹⁾	dB(A)	-	94	94	94	94	94	97	97	97	97
Sound pressure level at 1 m ⁽¹⁾	dB(A)	-	76	76	76	76	76	78	78	78	78
Dimensions - standard unit											
Length	mm	2724	3059	3059	3290	3290	3290	4730	4730	4730	4730
Width	mm	928	936	936	1069	1069	1069	1039	1039	1162	1162
Height	mm	1567	1743	1743	1950	1950	1950	1997	1997	2051	2051
Operating weight ⁽⁴⁾	kg	2157	3050	3050	3942	3977	3995	6932	7010	7665	7875
Compressors											
Semi-hermetic 06T screw compressors, 50 r/s											
Circuit A	-	1	1	1	1	1	1	1	1	1	1
Circuit B	-	-	-	-	-	-	-	1	1	1	1
Refrigerant - standard unit											
R1234ze											
Circuit A	kg	78	130	130	180	175	170	120	120	130	130
	teq CO ₂	0,5	0,9	0,9	1,3	1,2	1,2	0,8	0,8	0,9	0,9
Circuit B	kg	-	-	-	-	-	-	120	120	150	130
	teq CO ₂	-	-	-	-	-	-	0,8	0,8	1,1	0,9
Oil - standard unit											
HATCOL-4496											
Circuit A	l	20	20	20	25	25	25	20	20	25	25
Circuit B	l	-	-	-	-	-	-	20	20	20	25
Capacity control											
Touch Pilot, electronic expansion valves (EXV)											
Minimum capacity	%	15	15	15	15	15	15	10	10	10	10
Evaporator											
Multi-pipe flooded type											
Water volume	l	61	101	101	154	154	154	293	293	321	321
Water connections (Victaulic)	in	5	6	6	8	8	8	8	8	8	8
Drain and vent connections (NPT)	in	3/8	3/8	3/8	3/8	3/8	3/8	3/8	3/8	3/8	3/8
Max. water-side operating pressure	kPa	1000	1000	1000	1000	1000	1000	1000	1000	1000	1000
Condenser											
Multi-pipe flooded type											
Water volume	l	55	103	103	148	148	148	316	316	340	340
Water connections (Victaulic)	in	5	6	6	8	8	8	8	8	8	8
Drain and vent connections (NPT)	in	3/8	3/8	3/8	3/8	3/8	3/8	3/8	3/8	3/8	3/8
Max. water-side operating pressure	kPa	1000	1000	1000	1000	1000	1000	1000	1000	1000	1000

- (1) In dB ref=10⁻¹² W, (A) weighting. Declared dualnumber noise emission values in accordance with ISO 4871 (with an associated uncertainty of +/-3dB(A)). Measured in accordance with ISO 9614-1 and certified by Eurovent.
- (2) In dB ref 20μPa, (A) weighting. Declared dualnumber noise emission values in accordance with ISO 4871 (with an associated uncertainty of +/-3dB(A)). For information, calculated from the sound power level Lw(A).
- (3) Option 257 = Low noise level
- (4) Weight shown is guideline only. Please refer to the unit nameplate

ELECTRICAL DATA, STANDARD UNITS

30XW-PZE / 30XWHPZE		301	401	451	551	601	651	801	901	1001	1101
Power circuit											
Nom. power supply	V-ph-Hz	400-3-50									
Voltage range	V	360-440									
Control circuit											
24 V via the built-in transformer											
Nominal start-up current⁽¹⁾											
Circuit A	A	303	414	414	587	587	587	414	414	587	587
Circuit B	A	-	-	-	-	-	-	414	414	414	587
Option 81	A	-	-	-	-	-	-	529	543	716	751
Maximum start-up current⁽²⁾											
Circuit A	A	303	414	414	587	587	587	414	414	587	587
Circuit B	A	-	-	-	-	-	-	414	414	414	587
Option 81	A	-	-	-	-	-	-	597	621	794	855
Cosine phi											
Nominal ⁽³⁾		0,79	0,86	0,87	0,85	0,87	0,89	0,86	0,87	0,85	0,85
Maximum ⁽⁴⁾		0,90	0,90	0,90	0,90	0,90	0,90	0,90	0,90	0,90	0,90
Total harmonic distortion ⁽⁴⁾	%	Closed to 0% (negligible)									
Maximum power input⁽⁵⁾											
Circuit A	kW	86	112	126	148	165	174	112	126	148	148
Circuit B	kW	-	-	-	-	-	-	112	126	126	148
Option 81	kW	-	-	-	-	-	-	224	252	274	296
Nominal current drawn⁽³⁾											
Circuit A	A	91	115	129	164	177	194	115	129	164	164
Circuit B	A	-	-	-	-	-	-	115	129	129	164
Option 81	A	-	-	-	-	-	-	230	258	293	328
Maximum current drawn (Un)⁽⁵⁾											
Circuit A	A	140	180	205	240	268	282	180	205	240	240
Circuit B	A	-	-	-	-	-	-	180	205	205	240
Option 81	A	-	-	-	-	-	-	360	410	445	480
Maximum current drawn (Un -10%)⁽⁴⁾											
Circuit A	A	153	196	223	261	292	307	196	223	261	261
Circuit B	A	-	-	-	-	-	-	196	223	223	261
Option 81	A	-	-	-	-	-	-	392	446	484	522
Maximum power input with option 150B⁽⁵⁾											
Circuit A	kW	76	97	110	129	146	153	97	110	129	129
Circuit B	kW	-	-	-	-	-	-	97	110	110	129
Option 81	kW	-	-	-	-	-	-	195	220	239	258
Maximum current drawn (Un) with option 150B⁽⁵⁾											
Circuit A	A	123	158	179	209	237	249	158	179	209	209
Circuit B	A	-	-	-	-	-	-	158	179	179	209
Option 81	A	-	-	-	-	-	-	316	358	388	418

(1) Instantaneous start-up current (maximum operating current of the smallest compressor(s) + locked rotor current or reduced start-up current of the largest compressor). Values obtained at standard Eurovent conditions: evaporator entering/leaving water temp. = 12°C/7°C, condenser entering/leaving water temp. = 30°C/35°C.

(2) Instantaneous start-up current (maximum operating current of the smallest compressor(s) + locked rotor current or reduced start-up current of the largest compressor). Values obtained at operation with maximum unit power input.

(3) Values obtained at standard Eurovent conditions: evaporator entering/leaving water temp. = 12°C/7°C, condenser entering/leaving water temp. = 30°C/35°C.

(4) Values obtained at operation with maximum unit power input.

(5) Values obtained at operation with maximum unit power input. Values given on the unit nameplate.

PHYSICAL DATA, UNITS FOR HIGH CONDENSING TEMPERATURES

Standard-efficiency units (option 150)

30XW-ZE / 30XWHZE			301	401	451	551	601	651	801	901	1001	1101		
Heating														
Unit + option 150 Full load performances*	HW1	Nominal capacity	kW	315	475	521	658	716	774	919	1068	1127	1254	
		COP	kW/kW	5,74	6,01	6,00	5,76	5,74	5,79	5,88	6,02	5,88	5,68	
	HW2	Nominal capacity	kW	306	457	502	640	696	755	886	1027	1091	1217	
		COP	kW/kW	4,68	4,93	4,92	4,75	4,73	4,79	4,84	4,97	4,86	4,71	
	HW3	Nominal capacity	kW	298	442	485	621	678	736	856	986	1055	1178	
		COP	kW/kW	3,83	4,03	4,03	3,89	3,88	3,94	3,95	4,06	3,99	3,89	
	HW4	Nominal capacity	kW	290	428	469	602	662	717	831	952	1021	1140	
		COP	kW/kW	3,10	3,26	3,25	3,17	3,16	3,19	3,20	3,27	3,24	3,17	
	Seasonal energy efficiency**	HW1	SCOP _{30/35°C}	kWh/kWh	6,29	6,42	6,46	6,66	6,41	6,51	6,25	6,48	6,34	6,39
			ηs heat _{30/35°C}	%	227	242	243	251	241	245	235	243	238	240
		HW3	SCOP _{47/55°C}	kWh/kWh	4,81	4,87	4,90	5,06	4,88	4,98	4,88	5,10	5,00	5,07
			ηs heat _{47/55°C}	%	175	183	184	190	183	187	183	191	188	190
		Prated	kW	425	546	608	770	837	927	1085	1246	1378	1548	
Cooling														
Unit + option 150 Full load performances*	CW1	Nominal capacity	kW	265	404	444	556	606	655	781	915	962	1064	
		EER	kW/kW	4,94	5,22	5,23	4,96	4,96	5,02	5,14	5,36	5,18	4,99	
		Eurovent class		B	A	A	B	B	B	A	A	A	B	
	CW2	Nominal capacity	kW	375	578	637	767	834	892	1123	1313	1354	1464	
		EER	kW/kW	6,01	6,39	6,42	5,91	5,87	5,84	6,36	6,52	6,24	5,88	
		Eurovent class		A	A	A	A	A	A	A	A	A	A	
Seasonal energy efficiency	SEER_{12/7°C} Comfort low temp.		kWh/kWh	5,97	6,29	6,33	6,50	6,32	6,41	6,39	6,82	6,51	6,64	
	ηs cool_{12/7°C}		%	236	249	250	257	250	253	253	270	257	263	
	SEPR_{12/7°C} Process high temp.		kWh/kWh	7,02	7,11	7,18	7,44	7,10	7,26	6,93	7,34	7,27	7,21	

* In accordance with standard EN14511-3:2013

** In accordance with standard EN14825:2013, average climate

HW1 Heating mode conditions: Evaporator entering/leaving water temperature 10°C/7°C, condenser entering/leaving water temperature 30°C/35°C, evaporator and condenser fouling factor 0 m². k/W

HW2 Heating mode conditions: Evaporator entering/leaving water temperature 10°C/7°C, condenser entering/leaving water temperature 40°C/45°C, evaporator and condenser fouling factor 0 m². k/W

HW3 Heating mode conditions: Evaporator entering/leaving water temperature 10°C/7°C, condenser entering/leaving water temperature 47°C/55°C, evaporator and condenser fouling factor 0 m². k/W

HW4 Heating mode conditions: Evaporator entering/leaving water temperature 10°C/7°C, condenser entering/leaving water temperature 55°C/65°C, evaporator and condenser fouling factor 0 m². k/W

CW1 Cooling mode conditions: Evaporator water entering/leaving temperature 12°C/7°C, outside air temperature 35°C, evaporator fouling factor 0 m².K/W

CW2 Cooling mode conditions: Evaporator water entering/leaving temperature 23°C/18°C, outside air temperature 35°C, evaporator fouling factor 0 m².K/W

ηs heat_{30/35°C} & SCOP_{30/35°C} Applicable Ecodesign regulation: (EU) No 813/2013

ηs heat_{47/55°C} & SCOP_{47/55°C} Applicable Ecodesign regulation: (EU) No 813/2013

ηs cool_{12/7°C} & SEER_{12/7°C} Réglementation Ecodesign applicable (UE) No 2016/2281

SEPR_{12/7°C} Réglementation Ecodesign applicable (UE) No 2016/2281



Eurovent certified values

PHYSICAL DATA, UNITS FOR HIGH CONDENSING TEMPERATURES

Standard-efficiency units (option 150)

30XWHPZE		301	401	451	551	601	651	801	901	1001	1101
Sound levels - unit with option 150											
Sound power level ⁽¹⁾	dB(A)	93	97	97	100	100	100	100	100	103	103
Sound pressure level at 1 m ⁽²⁾	dB(A)	76	80	80	82	82	82	81	81	84	84
Sound levels - standard unit + option 257⁽³⁾											
Sound power level ⁽¹⁾	dB(A)	-	94	94	98	98	98	97	97	101	101
Sound pressure level at 1 m ⁽²⁾	dB(A)	-	76	76	80	80	80	78	78	82	82
Operating weight⁽⁴⁾	kg	2157	3050	3050	4102	4147	4175	6932	7010	7844	8182
Compressors											
Semi-hermetic 06T screw compressors, 50 r/s											
Circuit A	-	1	1	1	1	1	1	1	1	1	1
Circuit B	-	-	-	-	-	-	-	1	1	1	1
Refrigerant - unit with option 150											
R1234ze											
Circuit A	kg	78	130	130	180	175	170	120	120	130	130
	teq CO ₂	0,5	0,9	0,9	1,3	1,2	1,2	0,8	0,8	0,9	0,9
Circuit B	kg	-	-	-	-	-	-	120	120	150	130
	teq CO ₂	-	-	-	-	-	-	0,8	0,8	1,1	0,9
Oil - unit with option 150											
HATCOL-4496											
Circuit A	l	20	20	20	25	25	25	20	20	25	25
Circuit B	l	-	-	-	-	-	-	20	20	20	25
Capacity control											
Touch Pilot, electronic expansion valves (EXV)											
Minimum capacity	%	30	30	30	15	15	15	10	10	10	10
Evaporator											
Multi-pipe flooded type											
Water volume	l	61	101	101	154	154	154	293	293	321	321
Water connections (Victaulic)	in	5	6	6	8	8	8	8	8	8	8
Drain and vent connections (NPT)	in	3/8	3/8	3/8	3/8	3/8	3/8	3/8	3/8	3/8	3/8
Max. water-side operating pressure	kPa	1000	1000	1000	1000	1000	1000	1000	1000	1000	1000
Condenser											
Multi-pipe flooded type											
Water volume	l	55	103	103	148	148	148	316	316	340	340
Water connections (Victaulic)	in	5	6	6	8	8	8	8	8	10	10
Drain and vent connections (NPT)	in	3/8	3/8	3/8	3/8	3/8	3/8	3/8	3/8	3/8	3/8
Max. water-side operating pressure	kPa	1000	1000	1000	1000	1000	1000	1000	1000	1000	1000

(1) In dB ref=10⁻¹² W, (A) weighting. Declared dualnumber noise emission values in accordance with ISO 4871 (with an associated uncertainty of +/-3dB(A)). Measured in accordance with ISO 9614-1 and certified by Eurovent.

(2) In dB ref 20μPa, (A) weighting. Declared dualnumber noise emission values in accordance with ISO 4871 (with an associated uncertainty of +/-3dB(A)). For information, calculated from the sound power level Lw(A).

(3) Option 257 = Low noise level

(4) Weight shown is guideline only. Please refer to the unit nameplate

ELECTRICAL DATA, UNITS FOR HIGH CONDENSING TEMPERATURES

30XW-PZE / 30XWHPZE		301	401	451	551	601	651	801	901	1001	1101
Power circuit											
Nominal power supply	V-ph-Hz	400-3-50									
Voltage range	V	360-440									
Control circuit											
24 V via the built-in transformer											
Nominal start-up current⁽¹⁾											
Circuit A	A	388	587	587	629	629	629	587	587	629	629
Circuit B	A	-	-	-	-	-	-	587	587	587	629
Option 81	A	-	-	-	-	-	-	712	725	767	815
Maximum start-up current⁽²⁾											
Circuit A	A	388	587	587	629	629	629	587	587	629	629
Circuit B	A	-	-	-	-	-	-	587	587	587	629
Option 81	A	-	-	-	-	-	-	833	860	902	972
Cosine phi nominal⁽³⁾											
0,75 0,80 0,81 0,80 0,81 0,83 0,80 0,81 0,80 0,80											
Cosine phi maximum⁽⁴⁾											
0,90 0,90 0,90 0,89 0,89 0,89 0,90 0,90 0,90 0,89 0,89											
Total harmonic distortion⁽⁴⁾											
% Closed to 0% (negligible)											
Maximum power input⁽⁵⁾											
Circuit A	kW	107	144	158	202	219	228	144	158	202	202
Circuit B	kW	-	-	-	-	-	-	144	158	158	202
Option 81	kW	-	-	-	-	-	-	288	317	360	404
Nominal current drawn⁽³⁾											
Circuit A	A	102	125	138	186	197	213	125	138	186	186
Circuit B	A	-	-	-	-	-	-	125	138	138	186
Option 81	A	-	-	-	-	-	-	250	276	324	372
Maximum current drawn (Un)⁽⁵⁾											
Circuit A	A	174	234	257	328	356	371	234	257	328	328
Circuit B	A	-	-	-	-	-	-	234	257	257	328
Option 81	A	-	-	-	-	-	-	468	514	585	656
Max. current drawn (Un -10%)⁽⁴⁾											
Circuit A	A	190	255	280	357	387	404	255	280	357	357
Circuit B	A	-	-	-	-	-	-	255	280	280	357
Option 81	A	-	-	-	-	-	-	510	560	637	714

- (1) Instantaneous start-up current (maximum operating current of the smallest compressor(s) + locked rotor current or reduced start-up current of the largest compressor). Values obtained at standard Eurovent conditions: evaporator entering/leaving water temp. = 12°C/7°C, condenser entering/leaving water temp. = 30°C/35°C.
- (2) Instantaneous start-up current (maximum operating current of the smallest compressor(s) + locked rotor current or reduced start-up current of the largest compressor). Values obtained at operation with maximum unit power input.
- (3) Values obtained at standard Eurovent conditions: evaporator entering/leaving water temp. = 12°C/7°C, condenser entering/leaving water temp. = 30°C/35°C
- (4) Values obtained at operation with maximum unit power input.
- (5) Values obtained at operation with maximum unit power input. Values given on the unit nameplate.

ELECTRICAL DATA, UNITS FOR HIGH CONDENSING TEMPERATURES

Notes, electrical data and operating conditions 30XW-ZE

- As standard
30XW-PZE 301 to 651 units have a single power connection point located immediately upstream of the main disconnect switch.
30XW-PZE 801 to 1101 units have two connection points located immediately upstream of the main disconnect switches.
- The control box includes the following standard features:
 - One main disconnect switch per circuit*
 - Starter and motor protection devices for each compressor
 - Anti-short cycle protection devices*
 - Control devices
- Field connections:
All connections to the system and the electrical installations must be in full accordance with all applicable codes.
- The Carrier 30XW-ZE units are designed and built to ensure conformance with local codes. The recommendations of European standard EN 60204-1 (corresponds to IEC 60204-1) (machine safety - electrical machine components - part 1: general regulations) are specifically taken into account, when designing the electrical equipment.
- The absence of power supply disconnect switch(es) and short-cycle protection devices in option 82A is an important factor that has to be taken into consideration at the installation site.
Units equipped with one of these two options are supplied with a declaration of incorporation, as required by the machinery directive.

Notes:

- Generally the recommendations of IEC 60364 are accepted as compliance with the requirements of the installation directives. Conformance with EN 60204-1 is the best means of ensuring compliance with the Machines Directive.
- Annex B of EN 60204 1 describes the electrical characteristics used for the operation of the machines.

1. The operating environment for the 30XW-ZE units is specified below:
Environment** Environment as classified in EN 60721 (corresponds to IEC 60721):
 - indoor installation
 - ambient temperature range: minimum temperature +5°C to +42°C, class AA4
 - altitude: lower than or equal to 2000 m
 - presence of water: class AD2 (possibility of water droplets)
 - presence of hard solids, class 4S2 (no significant dust present)
 - presence of corrosive and polluting substances, class 4C2 (negligible)
2. Power supply frequency variation: ± 2 Hz.
3. The neutral (N) line must not be connected directly to the unit (if necessary use a transformer).
4. Overcurrent protection of the power supply conductors is not provided with the unit.
5. The factory installed disconnect switch(es)/circuit breaker(s) is (are) of a type suitable for power interruption in accordance with EN 60947-3 (corresponds to IEC 60947-3).
6. The units are designed for connection to TN networks (IEC 60364). For IT networks the earth connection must not be at the network earth. Provide a local earth, consult competent local organisations to complete the electrical installation.

NOTE: If particular aspects of an actual installation do not conform to the conditions described above, or if there are other conditions which should be considered, always contact your local Carrier representative.

* Not provided for units equipped with option 82A

** The required protection level for this class is IP21B or 1PX1B (according to reference document IEC 60529). All 30XW-ZE units fulfil this protection condition. In general the casings fulfil class IP23 or IPX3B.

PART LOAD PERFORMANCES

SCOP (In accordance with standard EN14825:2013, average climate)

The **SCOP (Seasonal Coefficient Of Performance)** permit evaluation of the average energy efficiency at part load, based on multipoint conditions (16°C to -10°C for average climate) and number of hours occurring at each air temperature (Bin hours).

To be able to compare the energy efficiency of boilers using a primary energy source (gas or fuel) with heat pumps using a final energy source (electricity), the seasonal efficiency criteria used by the Ecodesign regulations is known as it is based on the use of primary energy sources and expressed in %

The heat load of a building depends on many factors, such as the outside air temperature, the exposure to the sun and the building occupancy.

Consequently it is preferable to use the average energy efficiency, calculated at several operating points that are representative for the unit utilisation.

SEER for comfort chillers (in accordance with EU ECODESIGN)

The **SEER (Seasonal Energy Efficiency Ratio)** measures the seasonal energy efficiency of comfort **chillers** by calculating the ratio between annual cooling demand of the building and annual energy demand of the chiller. It takes into account the energy efficiency achieved for each outdoor temperature weighted by the number of hours observed for each of these temperatures, using actual climate data.

SEER is a new way of measuring the true energy efficiency of chillers for **comfort cooling** over an entire year.

This new indicator gives a more realistic indication of the real energy efficiency and environmental impact of a cooling system (Ecodesign Regulation 2016/2281).

SEPR for process chillers (in accordance with EU ECODESIGN)

The **SEPR (Seasonal Energy Performance Ratio)** measures the seasonal energy efficiency of **process chillers** by calculating the ratio between annual cooling demand of the process and annual energy demand of the chiller. It takes into account the energy efficiency achieved at each outdoor temperature of an average climate weighted by the number of hours observed for each of these temperatures.

SEPR is a new way of measuring the true energy efficiency of chillers for **process cooling** over an entire year. This new indicator gives a more realistic indication of the real energy efficiency and environmental impact of the cooling system (Ecodesign Regulation 2015/1095).

SOUND SPECTRUM

30XW-PZE / 30XWHPZE units

		Octave bands, Hz						Sound power levels	
		125	250	500	1k	2k	4k		
301	dB	71	88	88	91	85	67	dB(A)	93
401	dB	90	92	95	95	84	72	dB(A)	97
451	dB	90	92	95	95	84	72	dB(A)	97
551	dB	86	91	95	95	86	71	dB(A)	97
601	dB	86	91	95	95	86	71	dB(A)	97
651	dB	86	91	95	95	86	71	dB(A)	97
801	dB	93	95	98	98	87	75	dB(A)	100
901	dB	93	95	98	98	87	75	dB(A)	100
1001	dB	92	94	98	98	88	75	dB(A)	100
1101	dB	89	94	98	98	89	74	dB(A)	100

30XW-PZE / 30XWHPZE units with option 257*

		Octave bands, Hz						Sound power levels	
		125	250	500	1k	2k	4k		
301	dB	-	-	-	-	-	-	dB(A)	-
401	dB	90	91	91	91	82	72	dB(A)	94
451	dB	90	91	91	91	82	72	dB(A)	94
551	dB	86	90	91	91	84	71	dB(A)	94
601	dB	86	90	91	91	84	71	dB(A)	94
651	dB	86	90	91	91	84	71	dB(A)	94
801	dB	93	94	94	94	85	75	dB(A)	97
901	dB	93	94	94	94	85	75	dB(A)	97
1001	dB	91	94	94	94	86	74	dB(A)	97
1101	dB	91	94	94	94	86	74	dB(A)	97

* Option 257 = Low sound level

Note: The sound levels by octave bands are given for information only and not contractually binding. Only the global sound level is contractually binding.

30XWHPZE units with high condensing temperature (option 150)

		Octave bands, Hz						Sound power levels	
		125	250	500	1k	2k	4k		
301	dB	69	87	90	90	85	74	dB(A)	93
401	dB	90	92	95	95	84	72	dB(A)	97
451	dB	90	92	95	95	84	72	dB(A)	97
551	dB	83	96	98	97	89	74	dB(A)	100
601	dB	83	96	98	97	89	74	dB(A)	100
651	dB	83	96	98	97	89	74	dB(A)	100
801	dB	93	95	98	98	87	75	dB(A)	100
901	dB	93	95	98	98	87	75	dB(A)	100
1001	dB	88	99	101	100	92	76	dB(A)	103
1101	dB	88	99	101	100	92	76	dB(A)	103

30XWHPZE units with high condensing temperature (opt. 150)* and opt. 257*

		Octave bands, Hz						Sound power levels	
		125	250	500	1k	2k	4k		
301	dB	-	-	-	-	-	-	dB(A)	-
401	dB	90	91	91	91	82	72	dB(A)	94
451	dB	90	91	91	91	82	72	dB(A)	94
551	dB	83	96	94	96	88	73	dB(A)	98
601	dB	83	96	94	96	88	73	dB(A)	98
651	dB	83	96	94	96	88	73	dB(A)	98
801	dB	93	94	94	94	85	75	dB(A)	97
901	dB	93	94	94	94	85	75	dB(A)	97
1001	dB	88	99	97	99	91	75	dB(A)	101
1101	dB	88	99	97	99	91	75	dB(A)	101

OPERATING LIMITS AND OPERATING RANGES

Standard units

30XW-PZE / 30XWHPZE	Minimum	Maximum
Evaporator		
Entering temperature at start-up	-	35.0°C
Leaving temperature during operation	3.3°C	20.0°C
Entering/leaving temperature difference at full load	2.8 K	11.1 K
Condenser		
Entering temperature at start-up	13.0°C*	-
Leaving temperature during operation	19.0°C*	55.0°C
Entering/leaving temperature difference at full load	2.8 K	11.1 K

- * Use of antifreeze protection is required if the leaving temperature is below 3.3°C (Option 8).
- ** For lower condenser temperatures a water flow control valve must be used at the condenser (two or three-way valve). Please refer to option 152 to ensure the correct condensing temperature.
- *** Please refer to option 150 for applications with a high condenser leaving temperature (up to 70°C)

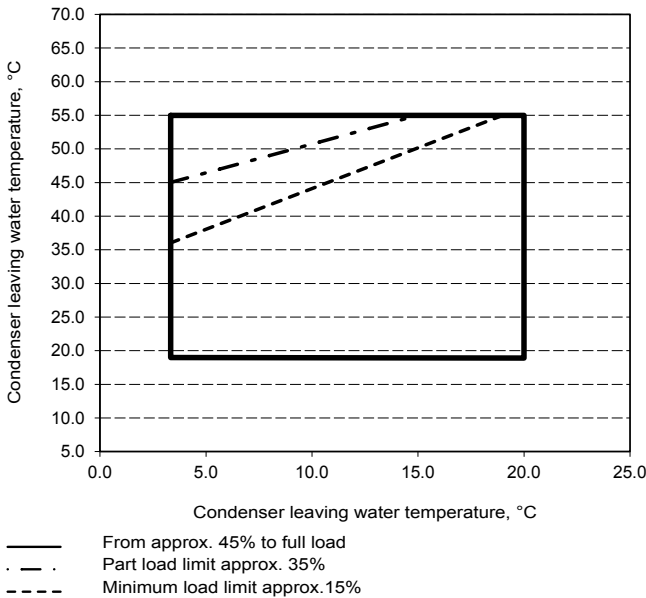

Option 150

30XW-PZE / 30XWHPZE	Minimum	Maximum
Evaporator		
Entering temperature at start-up	-	35.0°C
Leaving temperature during operation	3.3°C	20.0°C
Entering/leaving temperature difference at full load	2.8 K	11.1 K
Condenser		
Entering temperature at start-up	13.0°C*	-
Leaving temperature during operation	19.0°C*	70.0°C
Entering/leaving temperature difference at full load	2.8 K	11.1 K

- * For lower condenser temperatures a water flow control valve must be used at the condenser (two or three-way valve). Please refer to option 152 to ensure the correct condensing temperature.

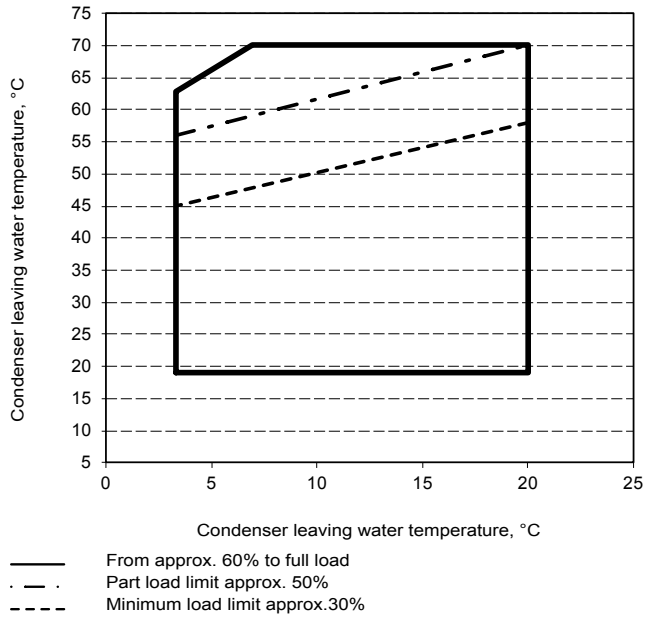

EVAPORATOR PRESSURE DROP CURVES

Units with two evaporator passes (standard):
30XW-PZE / 30XWHPZE

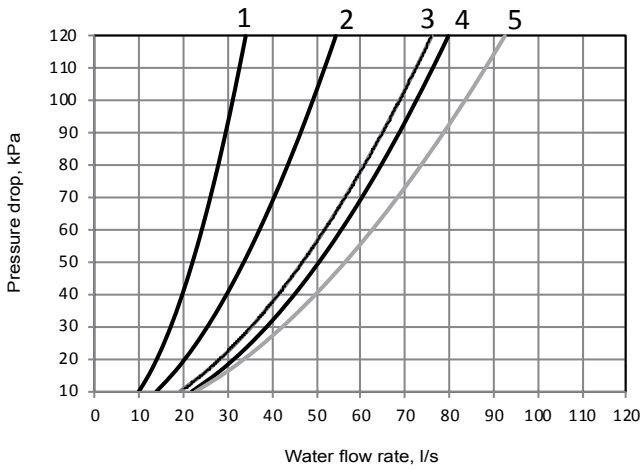

- Legend**
1. 301
 2. 401, 451
 3. 551, 601, 651
 4. 801, 901
 5. 1001, 1101

Units with one evaporator pass (option 100C):
30XW-PZE / 30XWHPZE

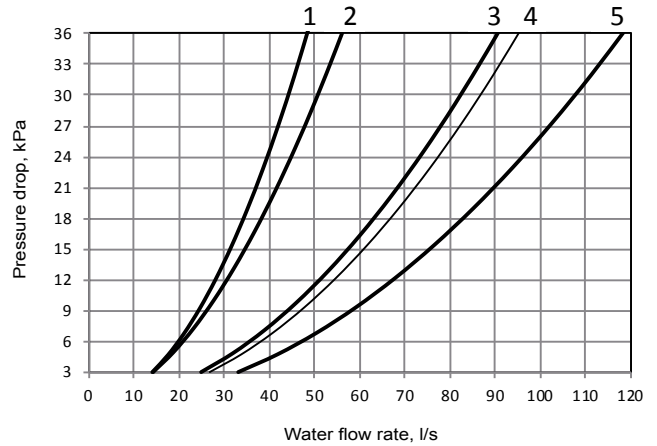

- Legend**
1. 301
 2. 401, 451
 3. 551, 601, 651
 4. 801, 901
 5. 1001, 1101

CONDENSER PRESSURE DROP CURVES

Units with two condenser passes (standard):
30XW-PZE / 30XWHPZE

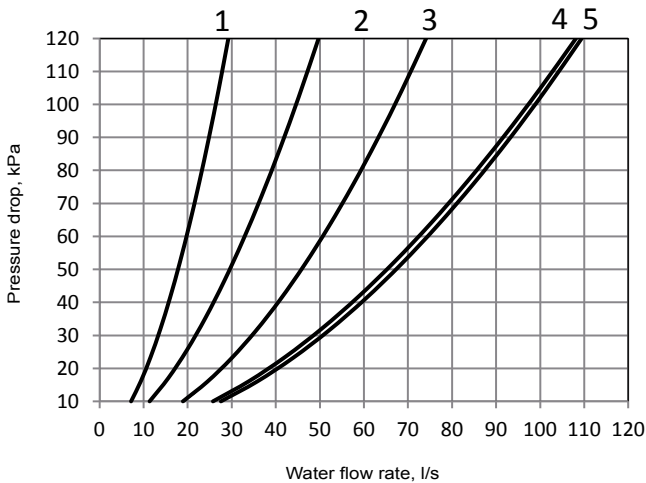

- Legend**
1. 301
 2. 401, 451
 3. 551, 601, 651
 4. 801, 901
 5. 1001, 1101

Units with one condenser pass (option 102C):
30XW-PZE / 30XWHPZE

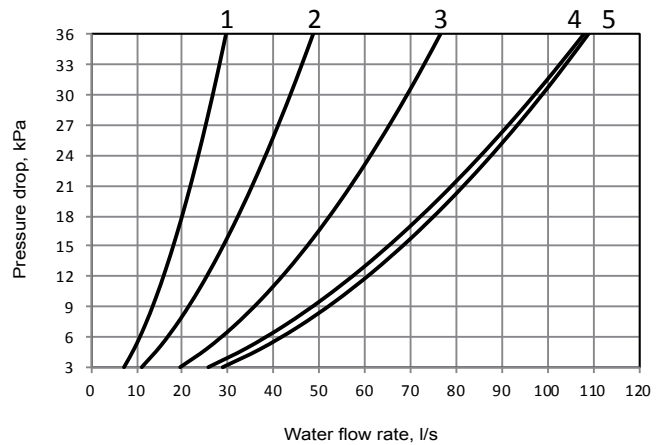

- Legend**
1. 301
 2. 401, 451
 3. 551, 601, 651
 4. 801, 901
 5. 1001, 1101

DIMENSIONS/CLEARANCES

30XW-PZE/30XWHPZE 301-651

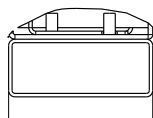
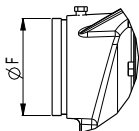
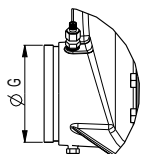
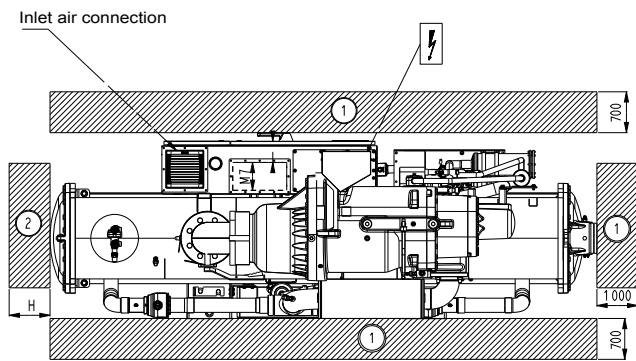
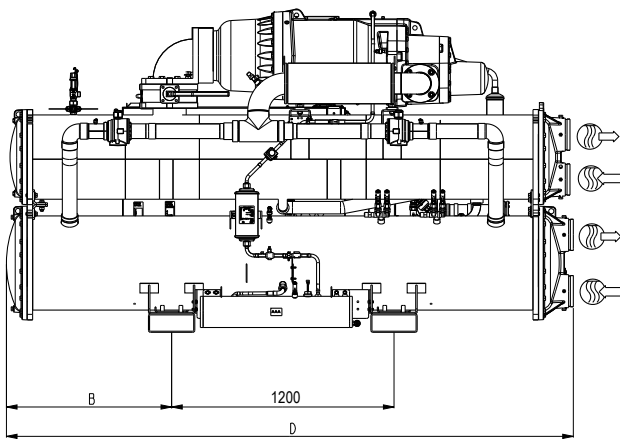
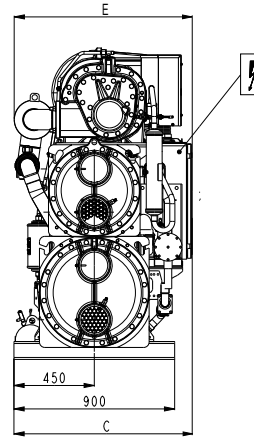
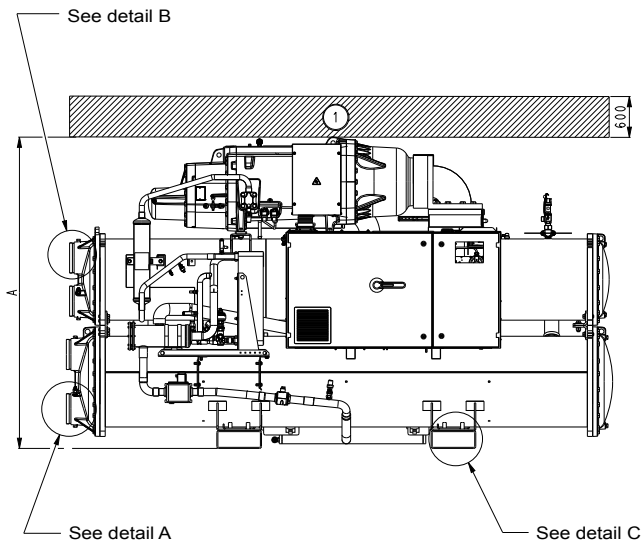

Detail A

Detail B

Detail C

Dimensions en mm								
	A	B	C	D	E	F	G	H
30XW-PZE / 30XWHPZE								
301	1612	800	982	2724	983	141,3	141,3	2600
401	1743	968	980	3059	982	168,3	168,3	2800
451	1743	968	980	3059	982	168,3	168,3	2800
551	1950	1083	1080	3290	1180	219,1	219,1	3100
601	1950	1083	1080	3290	1180	219,1	219,1	3100
651	1950	1083	1080	3290	1180	219,1	219,1	3100
30XW-PZE / 30XWHPZE (option 150)								
301	1612	800	982	2724	983	141,3	141,3	2600
401	1743	968	980	3059	982	168,3	168,3	2800
451	1743	968	1040	3059	1042	168,3	168,3	2800
551	1968	1083	1080	3290	1180	219,1	219,1	3100
601	1968	1083	1080	3290	1180	219,1	219,1	3100
651	1968	1083	1080	3290	1180	219,1	219,1	3100

Legend

All dimensions are given in mm

- ① → Services clearances required
- ② → Space required to remove cooler tubes
- Inlet water
- Outlet water
- Electrical supply entry

NOTES:

- Drawings are not contractually binding. Before designing an installation, consult the certified dimensional drawings supplied with the unit or available on request.
- For the positioning of the fixing points, weight distribution and centre of gravity coordinates please refer to the dimensional drawings.

DIMENSIONS/CLEARANCES

30XW-PZE/30XWHPZE 801-1101

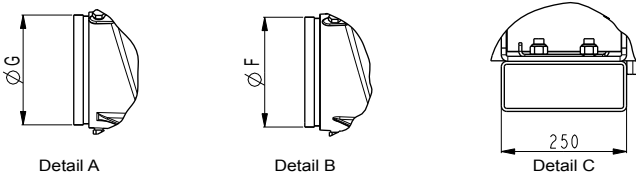
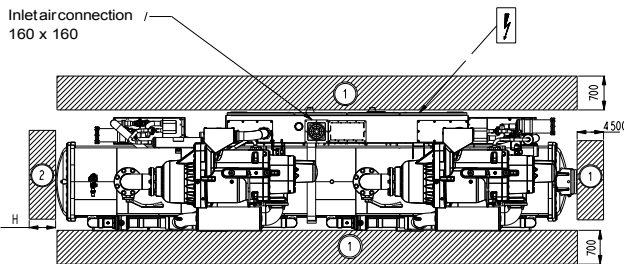
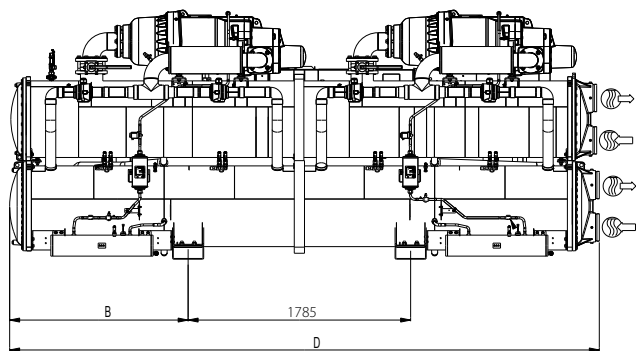
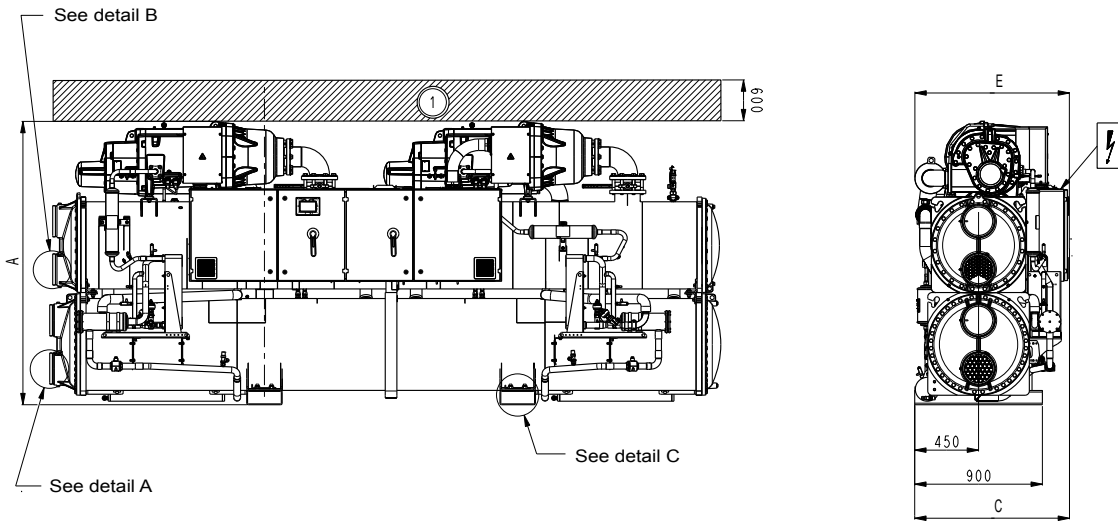

Dimensions en mm								
	A	B	C	D	E	F	G	H
30XW-PZE / 30XWHPZE								
801	1998	1512	1121	4730	1124	219,1	219,1	4500
901	1998	1512	1125	4730	1124	219,1	219,1	4500
1001	2051	1512	1238	4730	1238	219,1	219,1	4500
1101	2051	1512	1238	4730	1238	219,1	219,1	4500
30XW-PZE / 30XWHPZE (option 150)								
801	1998	1512	1121	4730	1124	219,1	219,1	4500
901	1998	1512	1125	4730	1124	219,1	219,1	4500
1001	2070	1512	1238	4730	1238	219,1	219,1	4500
1101	2051	1512	1238	4730	1238	219,1	219,1	4500

Legend

All dimensions are given in mm

- ① → Services clearances required
- ② → Space required to remove cooler tubes
- ⊕ → Inlet water
- ⊖ → Outlet water
- ⚡ → Electrical supply entry

NOTES:

- Drawings are not contractually binding. Before designing an installation, consult the certified dimensional drawings supplied with the unit or available on request.
- For the positioning of the fixing points, weight distribution and centre of gravity coordinates please refer to the dimensional drawings.

SPECIFICATION GUIDE

General description

- 30XW-PZE factory assembled single piece water-cooled chiller, shall include all factory wiring, piping, controls, refrigerant charge (HFO-1234ze), refrigeration circuits, screw compressors, electronic expansion valves and equipment required prior to field start-up.
- 30XWHPZE factory assembled single piece water-sourced heat pump, shall include all factory wiring, piping, controls, refrigerant charge (HFO-1234ze), refrigeration circuits, screw compressors, electronic expansion valves and equipment required prior to field start-up.

Quality assurance

Unit construction shall comply with European directives:

- From 1st January 2018, commission regulation (EU) N° 2016/2281 implementing Directive 2009/125/EC of the European Parliament and of the Council with regards to Ecodesign requirements for ENER Lot 21 comfort cooling chillers
- Commission Regulation (EU) N° 813/2013 implementing Directive 2009/125/EC of the European Parliament and of the Council with regard to Ecodesign requirements for space heaters and combination heaters
- Pressurized equipment directive (PED) 2014/68/EU
- Machinery directive 2006/42/EC, modified
- Low voltage directive 2014/35/EU, modified
- Electromagnetic compatibility directive 2014/30/EU, modified, and the applicable recommendations of European standards
- Machine safety: electrical equipment in machines, general requirements, EN 60204-1
- Electromagnetic compatibility emission EN61000-6-4
- Electromagnetic compatibility immunity EN61000-6-2
- Unit shall be designed, manufactured and tested in a facility with a quality management system certified ISO 9001 and environmental management system ISO 14001.
- Unit shall be run tested at the factory.

Design performance data

- Cooling capacity (kW):
- Unit power input (kW):
- Full load energy efficiency, EER (kW/kW):
- Eurovent Class
- Part load energy efficiency "comfort", SEER (kW/kW):
- Part load energy efficiency "process", SEPR (kW/kW):
- Heating capacity (kW):
- Full load energy efficiency, COP (kW/kW):
- Eurovent Class
- Part load energy efficiency, SCOP (kW/kW):
- Evaporator entering/leaving water temperature (°C): ... /
- Fluid type:
- Fluid flow rate (l/s):
- Evaporator pressure drops (kPa):
- Condenser entering/leaving water temperature (°C):
- Fluid type: R-1234ze (GWP < 1)
- Fluid flow rate (l/s):
- Condenser pressure drops (kPa):
- Sound power level at full load (dB(A)):
- Dimensions, length x depth x height (mm): ... x ... x

Performance shall be declared in accordance with EN14511-3:2013 and certified by Eurovent up to 1500 kW.

The unit shall be capable of starting with 13 °C entering water temperature to the condenser with condenser head pressure control option. The unit shall be capable of starting with 35 °C entering water temperature to the evaporator.

The machine shall operate with condenser leaving water temperature up to 55 °C.

- **(Carrier option 150)** The machine shall operate with condenser leaving water temperature up to 70 °C.
- **(Carrier option 8)** The unit shall permit chilled brine solution production down to -3 °C when ethylene glycol is used, or down to 0°C when propylene glycol is used.

Frame

- Machine frame shall include heat exchangers and compressors in a self-supporting structure
- Electrical panel doors shall be accessible by 1/4-turn screws

Compressor

- Unit shall have semi-hermetic twin-screw compressors with internal relief valve and check valve to avoid reverse rotation on shut down
- Each compressor shall be equipped with a discharge shut-off valve
- The discharge shall also be equipped with a muffler to reduce discharge gas pulsations
- Compressor bearings shall be designed for minimum 73000 hours at maximum operating conditions
- Capacity control shall be provided by a slide valve
- Compressor capacity control shall be stepless from 100% to 15% load
- Compressor shall start in unloaded condition
- Motor shall be cooled by suction gas and protected through a dedicated electronic board against the following: thermal overload by internal winding temperature sensors, electrical overload and short circuit by dedicated fuses (one per phase), reverse rotation, loss of phase, undervoltage and power supply failure
- Lubrication oil system shall include pre-filter and external filter capable of filtration to 5 microns
- The oil filter line shall be equipped with service shut off valves for easy filter replacement
- The oil separator, shall be integrated in the condenser design and shall not require oil pump
- The oil separator shall include an oil level safety switch.

Evaporator

- Unit shall be equipped with a single flooded evaporator
- Evaporator shall be manufactured by the chiller manufacturer
- Evaporator shall be tested and stamped in accordance with the European directive for pressurized equipment 2014/68/EU
- The maximum refrigerant-side operating pressure will be 2100 kPa, and the maximum waterside pressure will be 1000 kPa (2100kPa as an option)
- The evaporator shall be mechanically cleanable, shell-and-tube type with removable heads
- Tubes shall be internally and externally grooved, seamless-copper, and shall be rolled into tube sheets

SPECIFICATION GUIDE

- Shell shall be insulated with 19 mm closed-cell foam with a maximum K factor of 0.28. Evaporator thermal insulation shall be factory fitted
- The evaporator shall have a drain and vent in each head
- Chiller shall have only one water inlet & outlet connection with Victaulic couplings to avoid vibrations transmission and to accommodate minor pipework misalignment (Victaulic adapter kit shall be available on demand)
- The evaporator shall incorporate an indirect refrigerant level control system (based on the continuous measurement of the approach value) to ensure optimum heat transfer performance under all load conditions
- Design shall incorporate either 1 or 2 independent refrigerant circuits
- Evaporator shall be fitted with electronic auto setting water flow switch. Paddle switches or differential pressure switches shall not be acceptable.

Condenser

- Unit shall be equipped with a single condenser
- Condenser shall be manufactured by the chiller manufacturer
- Condenser shall be tested and stamped in accordance with the European directive for pressurized equipment 2014/68/EU
- Single pass or 2-passes design shall be possible
- The maximum refrigerant-side operating pressure will be 2100 kPa, and the maximum waterside pressure will be 1000 kPa (2100kPa as an option)
- The condenser shall be mechanically cleanable shell-and-tube type with removable heads
- Tubes shall be internally and externally grooved, seamless-copper, and shall be rolled into tube sheets
- The condenser shall have a drain and vent in each head
- Chiller shall have only one water inlet & outlet connection with Victaulic couplings to avoid vibrations transmission and to accommodate minor pipework misalignment (Victaulic adapter kit shall be available on demand)
- Design shall incorporate either 1 or 2 independent refrigerant circuits and the oil separator.

Refrigerant circuit

- Refrigerant circuit components shall include: compressor, oil separator, high and low side pressure relief devices, economizer, filter driers, moisture indicating sight glasses, long stroke electronic expansion device, and complete operating charge of both refrigerant R-1234ze and compressor oil
- **(Carrier option 92)** A compressor suction and discharge line shut off valve, an evaporator inlet valve and economizer line valve, shall be mounted to isolate all main components (filter drier, oil filter, expansion device and compressor) and allow refrigerant to be safely stored during service operation
- **(Carrier option 257)** Evaporator and refrigerant gas suction line shall be acoustically insulated.

Power control box

- Unit shall be supplied with specific electrical box with increased tightness, integrated blower and fresh air duct connection to maintain positive air pressure to avoid any risk of ignition.
- Unit shall operate at 400 Volts (+/- 10%), 3-phases, 50 Hertz power supply without neutral
- Unit shall be designed for simplified connection on TN(s) networks
- Control circuit voltage shall be 24 V maximum, supplied by a factory-installed transformer
- Unit shall be supplied with factory-installed main circuit breaker/isolator
- Unit shall have single point power connection (**Carrier option 81 for sizes 801/1101**)
- Unit shall have a factory installed star/delta starter as standard to limit electrical inrush current
- Power control box is powered painted with hinged and gasket sealed doors and is protected to IP23.

Controls

- Unit control shall include as a minimum: microprocessor with non-volatile memory, picture guided unit/operator interface, the LOCAL/OFF/REMOTE/CCN selector and a 5 inches coloured touch-screen display with multiple language capability
- Pressure sensors shall be installed to measure suction, discharge, and oil pressure
- Temperature probes shall be installed to read cooler/condenser entering and leaving temperatures.
- **(Carrier option 158A)** Unit control shall include as a minimum: microprocessor with non-volatile memory, picture guided unit/operator interface, the LOCAL/OFF/REMOTE/CCN selector and a 7 inches coloured touch-screen display with multiple language capability
- Unit control shall have an IP port to permit user connection via web browser, allowing same level of access to control menus as unit mounted interface (excluding start/stop and alarm reset capabilities)
- Control shall store technical documentation, drawings and spare parts list specific to each particular unit
- **(Carrier option 148B)** A two-directional communication board shall allow plug and play interfacing of the machine with any BMS using the J-Bus protocol
- **(Carrier option 148D)** A two-directional communication board shall allow plug and play interfacing of the machine with any BMS using the LonTalk protocol
- **(Carrier option 149)** Machine shall be supplied with factory-installed two-directional high-speed communication using BACnet protocol over Ethernet network (IP-connection). The BACnet over-IP communication shall have no limitation in reading/writing controller points and shall use standardized alarm codes as defined with BACnet protocol. Filed programming shall be required.
- **(Carrier option 298)** Machine shall be accessible via wireless connection for remote monitoring with the scope of preventive maintenance.

SPECIFICATION GUIDE

Unit shall be capable of performing the following functions:

- Electronic expansion valve control optimizing evaporator refrigerant charge while ensuring minimum refrigerant superheat and optimum subcooling at condenser outlet
- Capacity control based on leaving chilled fluid temperature
- Limitation of the chilled fluid-temperature pull-down rate at start-up to an adjustable range of 0.1°C to 1.1°C per minute to prevent excessive demand spikes at start-up
- Automatic change-over and cycling of compressors to equalize running hours and number of starts
- Reset enable of leaving chilled-water temperature based on the outdoor air temperature or via a 4-20 mA signal (as option)
- Dual set point management for the leaving chilled water temperature activated by a remote contact closure signal or by the built in time clock
- 2-level demand limit control (between 0 and 100%) activated by remote contact closure or by the built in time clock
- Time scheduling management to enable unit start-up control, demand limit and set-point changes
- Trending of main variables
- **(Carrier option 58)** lead/lag type control of two chillers running in series or parallel
- **(Carrier option 84)** Water pump control, safety pumps (if installed) on both condenser and cooler side
- **(Carrier option 156)** The following inputs contacts shall be available on the unit control board:
 - + Setpoint reset by indoor air temperature sensor
 - + Cooling setpoint reset by 4-20 mA
 - + Time schedule override
 - + Ice storage input
 - + Demand limit
 - + Unit shut down

The following outputs contacts shall be available on the unit control board:

- Instantaneous chiller capacity by 0-10 V signal
- Complete shut-down due to a chiller fault
- Compressor operation indication.

Diagnosis

- Control interface shall be capable of displaying set points, system status including temperatures, pressures, current for each compressor, run time and percent loading
- Control interface shall perform trending of up to 10 preselected variables
- Control system shall allow a quick test of all machine elements to verify the correct operation of every switch, circuit breaker, contactor etc. before the chiller is started
- In case of alarm, control system shall send an email to specific mail box set by user during machine commissioning
- Control shall have black box function which permit to store data set of 20 variables with interval of 5 seconds, during 14 minutes preceding the alarm and 1 minute following the alarm event. The black box recording capability shall permit recording for 20 events and once the threshold is reached new data shall over-write the oldest ones.

Safeties

Control system shall provide the unit with protection against the following:

- Reverse rotation
- Low chilled water temperature
- Low oil pressure (per compressor)
- Current imbalance
- Compressor thermal overload
- High pressure (with automatic compressor unloading in case of excessive condensing temperature)
- Electrical overload and short circuit
- Loss of phase, undervoltage and power supply failure

Control shall provide separate general alert (minor incident) and alarm (circuit down) remote indication.



Order No.: 10133, 03.2018. Supersedes order No.: 10133, 05.2016.
Manufacturer reserves the right to change any product specifications without notice.

Manufactured by: Carrier SCS, Montluel, France.
Printed in the European Union.



Quality and Environment
Management Systems
Approval